

Selection and Application of Microorganisms to Improve Oil Recovery

By P. F. Almeida, R. S. Moreira, R. C. C. Almeida, A. K. Guimarães, A. S. Carvalho, C. Quintella, M. C. A. Esperidiã, and C. A. Taft*

Microbial enhanced oil recovery (Meor) is an incontestably efficient alternative to improve oil recovery, especially in mature fields and in oil reservoirs with high paraffinic content. This is the case for most oil fields in the Recôncavo basin of Bahia, Brazil. Given the diverse conditions of most oil fields, an approach to apply Meor technology should consider primarily: (i) microbiological studies to select the appropriate microorganisms and (ii) mobilization of oil in laboratory experiments before oil field application. A total of 163 bacterial strains, selectively isolated from various sources, were studied to determine their potential to be used in Meor. A laboratory microbial screening based on physiological and metabolic profiles and growth rates under conditions representative for oil fields and reservoirs revealed that 10 bacterial strains identified as *Pseudomonas aeruginosa* (2), *Bacillus licheniformis* (2), *Bacillus brevis* (1), *Bacillus polymyxa* (1), *Micrococcus varians* (1), *Micrococcus* sp. (1), and two *Vibrio* species demonstrated potential to be used in oil recovery. Strains of *B. licheniformis* and *B. polymyxa* produced the most active surfactants and proved to be the most anaerobic and thermotolerant among the selected bacteria. *Micrococcus* and *B. brevis* were the most salt-tolerant and polymer producing bacteria, respectively, whereas *Vibrio* sp. and *B. polymyxa* strains were the most gas-producing bacteria. Three bacterial consortia were prepared with a mixture of bacteria that showed metabolic and technological complementarity and the ability to grow at a wide range of temperatures and salinity characteristics for the oil fields in Bahia, Brazil. Oil mobilization rates in laboratory column experiments using the three consortia of bacteria varied from 11.2 to 18.3 % [v/v] of the total oil under static conditions. Consortia of *B. brevis*, *B. licheniformis* and *B. polymyxa* exhibited the best oil mobilization rates. Using these consortia under anaerobic conditions could be an interesting alternative for Meor technology because their growth could be easily controlled through the administration of phosphate and inorganic electron acceptors. Bacterial strains selected in this work could be valuable for further application in oil recovery at productive and mature oil well sites as well as for the prevention and control of paraffin deposits.

1 Introduction

Most oil fields in the Recôncavo basin of Bahia (Brazil) are mature, have high content of paraffin (26 % w/v), with an elevated flow point (36 °C), and a cloud point of between 44 and 48 °C. This can cause paraffin crystallization [1] and the formation of deposits on the surfaces of the transport equipment, thus hindering the oil recovery by conventional primary and secondary techniques [2]. In turn, this results in a drastic reduction of yields [3].

To improve the yields, oil-releasing microorganisms can be employed through Meor technology. Microbial processes involve the use of thermotolerant aerobic and facultative anaerobic species of *Pseudomonas*, *Bacillus*, *Acinetobacter*, *Nocardia*, *Rhodococcus*, sulfide oxidizing bacteria, certain strains of fermenting bacteria, methanogenic thermophilic

as well as extremophilic bacteria such as hyperthermophiles [4–9]. They can be either native or selected from other ecosystems. Many of these species have the capacity to oxidize reduced sulfur compounds by using nitrate as an electron acceptor [10], while others have the ability to use hydrogen produced fermentatively for the reduction of inorganic oxidized compounds such as S, N or oxygen [11]. In some field applications, nutrients for growth are additionally supplied via the injection of a low-cost fermentable carbohydrate, vitamin and/or inorganic compounds as substrates for microbial growth [4, 12]. The environmental parameters of the reservoir – such as temperature, permeability, acidity, and salinity – usually limit the types of microorganisms that can be used for *in-situ* processes [13, 14]. Thus, isolation and appropriate screening procedures for bacterial selection are important steps to conduct a successful oil recovery technology.

The mechanisms by which microbial consortia work can be quite complex and may involve multiple biochemical processes. Once established in the well and reservoir areas, bacteria are able to metabolize nutrients, even hydrocarbons, and excrete by-products *in situ* such as surfactants, polymers, acids, gases and solvents [15]. These microbial products change the chemical and physical properties of the oil as well as the reservoir environment, thus improving oil production [15, 16]. Some microbial surfactants can also signifi-

[*] P. F. Almeida, R. S. Moreira, R. C. C. Almeida, A. K. Guimarães, A. S. Carvalho, Laboratório de Biotecnologia e Ecologia de Microorganismos da Universidade Federal da Bahia, Avenida Reitor Miguel Calmon, s/n, Vale do Canela, CEP 41.160–100 Salvador BA, Brasil; C. Quintella, M. C. A. Esperidiã, Instituto de Química da Universidade Federal da Bahia, Rua Barão de Geremoabo, s/n, Campus Universitário de Ondina, CEP 40.170–290, Salvador BA, Brasil; C. A. Taft (author to whom correspondence should be addressed, e-mail: taft@cbpf.br), Centro Brasileiro de Pesquisas Físicas, Rua Dr. Xavier Sigaud, 150, Urca, 22290–180, Rio de Janeiro, Brasil.

cantly improve oil production by contributing to the removal of suspended debris and paraffin from the near-well bore region [17]. Microbial surface-active agents and biosolvents enhance oil production by reducing the viscosity of heavy oils [18], thus promoting the emulsification of crude oil [19] and altering the relative permeability of the reservoir rock to increase the displacement of oil from the rock [2,17]. Gases and acids have also been important factors in Meor technology [17,20,21]. Many bacterial species produce polymers that could be used *in situ* to plug high permeability streaks in the reservoir preferentially and thus improve sweep efficiency by promoting fluid diversion [2]. Addition of N and P inorganic compounds to the mature oil fields that improves oil recovery (probably by stimulating native-petrobiotic bacteria) has also been used. Thus, by continuing to produce desirable by-products *in situ*, the microorganisms can mobilize the oil once considered lost. Some reports have recently demonstrated that certain strains of *B. licheniformis* produce biosurfactants, polymers and biosolvents in addition to having the ability to degrade and consume hydrocarbons [3].

Pools of microorganisms have been applied at more than 300 oil-producing wells in Venezuela to increase oil recovery. This application resulted in a 78 % success rate and production increase ranging from 30 to 400 additional barrels of oil per day [12]. Bacteria can thrive for many months or even years [22] resulting in more pronounced and lasting effects than those achieved with conventional heat and chemical treatments.

This research was carried out to isolate, select and evaluate bacterial strains for their potential to be used in microbial enhanced oil recovery processes in wells, fields, and reservoirs in the Recôncavo Basin of Bahia, Brazil.

2 Materials and Methods

2.1 Samples, Bacterial Isolation, Selection and Identification

Samples of crude oil from wells, ground contaminated with hydrocarbons, and chemical surfactants out of specifications were aseptically collected in sterile bottles and sent to the laboratory where they were immediately analyzed. Selected pure cultures from our laboratory were also included in this study. Procedures for bacterial isolation involved direct isolation and enrichment cultures [7]. Stock cultures were maintained in 0.5× nutrient agar (Difco™) slants and stored at 4 °C throughout the course of this study. Cultures were activated in 0.5× nutrient broth overnight at 37 °C.

Emulsification Activity

Five isolated colonies from each plate were primarily evaluated for their emulsification activity in mineral medium [7]; these evaluations were subsequently confirmed by surface tension measurements.

Production of Biopolymer, Acid and Gas from Glucose and Sulfide as well as Motility Tests

Activated cultures were submitted to glucose fermentation, motility and production of H₂S by standard methods [23]. Cultures were checked for polymer production by streaking an inoculum on 0.5× nutrient agar supplemented with glucose at 4 %, incubated at 37 °C for 48 hours.

Growth at Various Temperatures and Salt Concentrations

The effects of extreme conditions were investigated in 0.5× nutrient broth supplemented with 1 % glucose. The effects of temperature were measured by inoculating activated cultures in broth tubes incubated at 37, 45, 50, 55 and 60 °C for 3 days. The tests for growth in varying salinity were carried out in the same broth supplemented with 3, 5, 7, and 10 % NaCl concentrations and the tubes were incubated at 37 °C for 3 days. Positive growth was considered when the tubes were turbid after the incubation period.

Confirmation of the Surfactant Activity

Selected cultures were inoculated in modified 0.5× nutrient broth with 10 % hexane at 30 °C per 72 hours in a shaker, followed by a centrifugation step (10 min at 12,000 × g per 10 min at 4 °C), and the supernatant was collected. The surface tension was measured in 20 mL of each culture's supernatant in an annular tensiometer (DuNoy) at 25 °C. Cultures that reduced the surface tension to values less than 40 mN/m were submitted to kinetic analysis of the surfactant production [24]. For the most active surfactant, which lowered the surface tension from 66 to 37 mN/m, the total yield of surfactant was measured using a standard technique [25].

Bacterial Identification

Microorganisms with potential to be used in Meor were characterized using standard microbiological techniques [23,26] and identified according to Bergey's Manual of Determinative Bacteriology [27] and confirmed by fatty acid methyl esters (FAME) analysis using the protocols of the Microbial Identification System (MIDI; Microbial Identification, Newark, DE, USA).

2.2 Evaluation of Selected Surfactant-Producing Bacteria for an Experimental Oil Recovery Process

Bacterial Consortia and the Preparation of the Inoculum

Three bacterial consortia were constructed. Consortium 1 consisted of a mixture of *Bacillus polymyxa*, *Bacillus brevis*,

Micrococcus varians, *Micrococcus* sp., and *Pseudomonas aeruginosa* strains 38H and 44C, *Vibrio* sp. strains 36H and 33C; Consortium 2 included *B. brevis*, *B. licheniformis* strain 2P and *B. polymyxa*; for Consortium 3, the following strains were used: *Bacillus brevis*, *B. licheniformis* strain 2P, *Vibrio* sp. strain 36H and *P. aeruginosa* strain 44C. The control did not contain bacteria. 100 μ L of each activated culture was inoculated in 10 mL of mineral media [28] modified by adding yeast extract 0.1 g/L and glucose 0.5 g/L (MMM). Each strain grew overnight at 35 °C shaking routinely in the same MMM. For the oil recovery experiments, 500 μ L of each culture was inoculated in Erlenmeyer flasks containing 50 mL of MMM with 10 % hexane. Flasks were incubated at 35 °C, while being shaken at 120 rpm for 24 hours.

Recovery Experiments

Except for the control, an inoculum of 10 mL of each activated culture was aseptically injected into a laboratory test column (see Fig. 1) containing 1 L of paraffin oil supplemented with 2 % [w/v] sterile sugar cane molasses. The potential of the bacterial consortia was evaluated by measuring the volume of oil recovered in the collector (see Fig. 1) after one week of incubation at room temperature (28 to 32 °C).

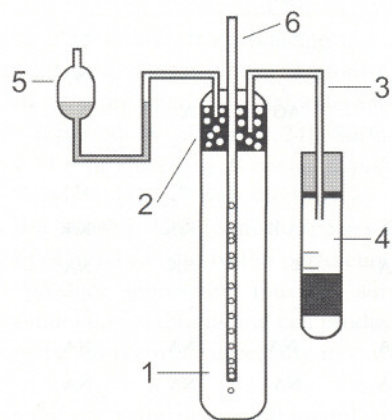

Figure 1. Laboratory column used for the evaluation of selected bacterial cultures based on oil recovery. (1) Column full with saturated sand oil; (2) Fiber buffer for filtration of mobilized fluids; (3) Oil and gas tube collector from the microbial recovery process; (4) Collector with a scale to measure recovered oil; (5) Special collector to indicate gas formation; (6) Sample injector.

3 Results and Discussion

3.1 Isolation and Screening of Bacteria Based on the Emulsification Ability

A total of 163 isolates or cultures were studied and 60 showed emulsification ability. Contaminated ground was the main source of surfactant-producing bacteria. One sample of paraffin oil originated two strains of active surfactant-producing bacteria. For the isolation of the bacteria from oil

samples, including one surfactant producing bacterium, the enrichment technique was necessary. After the primary isolation of the cultures from oil samples, the growth rates sped up and a high-yield biomass was obtained at 24 h of incubation. Microorganisms originating from samples submitted to selective factors (ground oil spill and surfactant) also exhibited higher emulsifying ability as has been demonstrated by others [29]. Direct and enrichment cultures produce many microorganisms with emulsifying ability pertaining to a wide heterogeneity of bacterial species and metabolic profile reflection from the origin of ecosystems studied as reported by other authors [2, 30].

Production of Biopolymers, Acids and Gas from Glucose and Sulfide as well as Motility and Growth at Various Temperatures and Salt Concentrations

Analysis of the metabolic and physiological profiles of the 60 strains revealed that 31 (52 %) of the cultures were motile, 34 (57 %) produced acid and gases from glucose fermentation and 32 (53 %) accumulated slime on the colonies. Only 13 (22 %) of the isolates produced sulfide. Most bacterial isolates reduced nitrate, which renders them useful for Meor application because of the possibility of controlling their growth in the reservoir. Although half of the isolated microorganisms produced acid, gas, and polymers from glucose metabolism, many of them were discarded because they did not show other desired properties, such as growth under the environmental conditions in wells, fields and reservoirs, especially at 45 °C and 5 % salinity or because they exhibited undesirable features, such as hydrogen sulfide production. Colonies of *B. brevis* (strain 13C) and *B. polymyxa* (strain 2C) produced the greatest amounts of polymers. Technological properties (such as polymer, acid and gas production as well as growth at maximal temperature and salinity) of the media close to those of the reservoir are important criteria for the selection of the most appropriate microorganisms being considered for Meor. Also important is the guarantee that such organisms are not H₂S producers due to their harmful effects on the petroleum processing. One microorganism identified as *Bacillus brevis*, a strong polymer producer, could be important to the Meor technology. Many bacterial species produce polymers that could be used *in situ* to preferentially plug high permeability streaks in the reservoir and thus improve sweep efficiency by promoting fluid diversion [2]. Polymers are also used to treat production wells to reduce water production and operating costs prolonging the economic life of the wells [22]. Polymers were also produced at the temperature, salinity and the anaerobic conditions of the reservoir using nitrate as an electron acceptor (data not shown). Furthermore, polymer function as energetic reserve to support bacterial growth at starvation conditions and, most important, to maintain bacteria attached to rock surfaces [13].

Confirmation of the Surfactant Activity

The laboratory screening was refined by surface tension activity evaluation. Among the 60 strains only 15 (25 %) reduced the surface tension down to 29 and 11 mN/m in comparison to the control (66 mN/ml). These microorganisms could be used in Meor systems due to their ability to reduce surface tension below 10 mN/m [7]. Strains 2P and 6P (both identified as *Bacillus licheniformis*) as well as strain 2C (identified as *Bacillus polymyxa*) exhibited the greatest surfactant activities reducing the surface tension from 66 to 37–40 and 41 mN/m, respectively (see Tab.1). Surfactant production by strain 2P of *B. licheniformis* occurred both aerobically and anaerobically reaching maximum production at 18 hours of incubation (see Fig. 2).

Surfactant production by *B. licheniformis* 2P was higher under aerobic rather than anaerobic growth conditions reaching a maximum surfactant activity of 35 and 41 mN/m, respectively. These results are very similar to those reported by Yakimov *et al.* [24], except that their surfactants were more potent than those found in this work. The total yield of surfactant (lipopeptide) from *B. licheniformis* was found to be 0.7 g/L of minimal broth, which is similar to that obtained by Maker & Camorra [31]. The surface-active properties are essential for the recovery and production of petroleum from oil reservoirs [19] because a biosurfactant can reduce the viscosity of heavy oils by as much as 95 % [18]. It can also promote emulsification of crude oil [32] and alter the relative permeability of the rock to oil by changing the wettability of the reservoir rock [2] and thus facilitating the

Table 1. Bacterial species with potential to be used in microbial enhanced oil recovery technology.

Sample	13C	2C	2P	6P	17C	7 I	36H	38H	44C	33C
Shape/Gram	R/+	R/+	R/+	R/+	C/+	C/+	R/-	R/-	R/-	R/-
Arrangements	I	I	I	I	T	T	I	I	I	I
Spore	SC	OC	SST	SST	-	-	-	-	-	-
Swelling Sporangium	+	+	-	-	NA	NA	NA	NA	NA	NA
Catalase	+	+	+	+	+	+	NA	NA	NA	NA
Oxidase	+	+	+	+	-	-	+	+	+	+
Citrate	-	-	+	+	-	-	+	NA	NA	+
Glucose	A	AG	A	A	A	A	AG	A	A	AG
H ₂ S production	-	-	-	-	-	-	-	-	-	-
Nitrate reduction	+*	+*	+*	+*	+	-	+	+*	+*	+
TSI agar	A/K	A/G	A/A	A/A	NA	NA	A/K	K/K	K/K	A/K
Indol	+	-	-	-	NA	NA	+	NA	NA	-
Motility	+	+	+	+	-	-	+	+	+	+
VP	+	+	+	+	NA	NA	NA	NA	NA	NA
Gelatine	+	+	+	+	NA	NA	NA	NA	NA	NA
Growth at:										
30 °C to 45 °C	+	+	+	+	+	+	+	+	+	+
50 °C	+	+	+	+	-	-	+	+	+	+
55 °C	-	-	+	+	-	-	-	-	-	-
60 °C	-	-	-	-	-	-	-	-	-	-
NaCl 3 to 5 %	+	+	+	+	+	+	+	+	+	+
NaCl 7 %	-	-	+	+	+	+	-	+	+	+
NaCl 10 %	-	-	-	-	+	+	-	-	-	-
Anaerobic growth	-**	+	+	+	+	+	+	+	+	+
ST [mN/m]	54	41	37	40	52	48	49	50	40	51
Probable species	<i>Bb</i>	<i>Bp</i>	<i>Bl</i>	<i>Bl</i>	<i>Mv</i>	<i>Ms</i>	<i>Vs</i>	<i>Pa</i>	<i>Pa</i>	<i>Vs</i>

R rods; C cocci; I isolated; T tetrad; S Spherical; SC Spherical Central; SST Spherical Subterminal; + positive reaction; - negative reaction; A acid; G gas; K Alkaline; NA not applicable; ST surface tension; probable species: *Bb* (*Bacillus brevis*).

* Production of gas from nitrate; ** It grows anaerobically in the presence of nitrate; *Bp* (*Bacillus polymyxa*); *Bl* (*Bacillus licheniformis*); *Mv* (*Micrococcus varians*); *Ms* (*Micrococcus* sp.); *Vs* (*Vibrio* sp.); *Pa* (*Pseudomonas aeruginosa*).

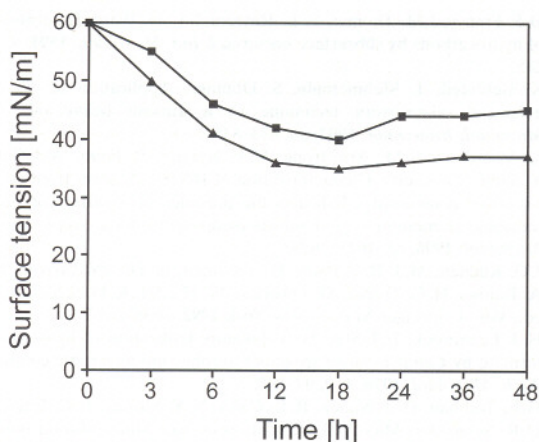

Figure 2. Kinetics of surfactant production of strain 2P of *Bacillus licheniformis*. Biosurfactant activity as determined by measuring changes in surface tension under aerobic (▲) and anaerobic (■) conditions as described by Yakimov *et al.* 1997 [21].

displacement of oil from the rock. These organisms also grew at temperatures and salt concentrations usually found in the environment of most wells and oil reservoirs in the Recôncavo basin of Bahia that make them useful to the Meor technology. In addition, the strains of *B. licheniformis*, isolated from the paraffin oil, grew well at 55 °C and at 7 % of NaCl (see Tab.1). According to our results, strains of *B. licheniformis* are potentially useful for the *in-situ* Meor approach because in addition to producing the most effective biosurfactant [24], the organism demonstrated other properties such as being anaerobic, halotolerant, and thermotolerant as reported by others [2,24]. Surfactants and polymers were also produced by *B. brevis*, *B. polymyxa* and *B. licheniformis* when nitrate was supplied as a nitrogen source (data not shown). Furthermore, species of *Bacillus* have a greater potential for survival in petroleum reservoirs because they produce spores and thus can survive more stressful environmental conditions and can produce acid and solvents improving oil recovery especially in carbonate formations.

Tab.1 shows the characterization and identification of ten bacterial strains that were selected due to their superior profiles for Meor technology. These organisms were bacteriologically identified and confirmed by MIDI as *Pseudomonas aeruginosa* (2), *Bacillus licheniformis* (2), *Bacillus brevis* (1), *Bacillus polymyxa* (1), *Micrococcus varians* (1), *Micrococcus* sp. (1), and *Vibrio* sp. (2). Strains of *B. licheniformis*, *P. aeruginosa* and the two *Vibrio* species were differentiated based on their ability to reduce the surface tension. Species of *Micrococcus* were the most salt-tolerant, being able to grow at up to 10% NaCl. *Vibrio* sp. and *B. polymyxa* were the most gas-producing bacteria, whereas *B. brevis* showed a huge production of slime visible in its appearance. This property could allow this bacterium to plug faults in reservoirs. All bacteria presented surfactant activity and the growth was not inhibited by high NaCl concentrations (up to 5 %) and up to 45 °C. The organisms could be used in wells and

oil reservoirs under environmental conditions found in the Recôncavo basin of Bahia.

Our results indicate that all three bacterial consortia were capable of recovering oil experimentally compared to the control. Consortium 1, composed of all bacterial species, except *B. licheniformis* and *B. polymyxa*, presented a recovery rate of 11 %. Consortium 2 containing only the isolates of *B. brevis*, *B. polymyxa* and one strain of *B. licheniformis* demonstrated the best recovery potential, mobilizing the oil at an exceptionally high rate, 18 %. Consortium 3 made up of *B. brevis*, *B. licheniformis*, *P. aeruginosa* and a *Vibrio* species recovered 16 % of the oil. Furthermore, the production of solvents and surfactant as well as acid and gases from glucose and nitrogen metabolism by *B. polymyxa* could be responsible for the additional oil recovery by the bacteria of Consortium 2. This could be due to the increase of pressure, viscosity reduction and oil solubilization, thus improving the flow across the laboratory column. Gas production (primarily CO₂) is an important characteristic that could improve oil recovery by increasing reservoir pressure and by reducing the viscosity and swelling of individually trapped droplets of crude oil caused by solubilization of gas and thus improving flow across the rocks [15,8]. Our results are in agreement with those presented by Jack *et al.* [20] that demonstrated that the "*in-situ*" production of gas was the main factor responsible for enhancing additional liberation of the oil due to the properties related above. Microbes also produce gases such as H₂, CO, CH₄ and N₂, which could also contribute to increasing the oil recovery.

Bacteria growing in a reservoir can lead to formation plugging, biodegradation of injected chemicals *in situ*, and souring of production wells where sulfate-reducing bacteria are actively generating H₂S [16]. In Bahia, some oil fields have been facing these problems. Recently, our laboratory has developed a few processes, including the biocompetitive exclusion technology to control these undesirable organisms (data not shown). In addition, pump and filter clogging through the formation of slime, fouling of interior pipe surfaces, and general cleaning problems in downstream oil and fuel handling facilities can result from the growth of some bacteria [16].

Yakimov *et al.* [21] verified under experimental conditions, simulating reservoir conditions, that one strain of *B. licheniformis* produced significant biomass, polymer, alcohol, and acids. Oil recovery (core flooding) experiments with this strain on a sucrose-based nutrient were performed with lime-free and lime-containing, oil-bearing sandstone cores. Although using different systems, the oil recovery efficiencies of our work were close to the results of Yakimov *et al.* [21] that varied from 9.3 to 22.1 % of the water flood residual oil saturation.

The combination of *Bacillus* species producing surfactants, polymers, acids, gases, and alcohols, associated with their ability to grow under conditions found in most reservoirs make them applicable for Meor technology. It should be emphasized that *B. polymyxa* has the ability to fix nitrogen

when grown under anaerobic conditions and all spore-forming *Bacillus* species can also grow anaerobically at the expense of non-fermentable substrates when furnished with nitrate due to their high denitrification activities. Exploration of these metabolic properties could be important in microbial processes employing *Bacillus* species to enhance oil recovery.

4 Conclusions

The isolation and identification procedures used in this work proved to be effective for the appropriate selection of a variety of bacteria from various ecosystems that showed complementary metabolic and physiological properties. Based on technological selection of the spore-forming microorganisms, of surfactants and polymer producers, of gas and acid producing microbial species as well as nitrate reducing *Bacillus* bacteria, consortia capable of mobilizing oil were constructed in laboratory columns with characteristics similar to those achieved by Yakimov *et al.* [24] and Lazar *et al.* [3]. Now research is being conducted to verify the ability of those and other organisms in core flooded experiments filled with paraffinic oil to evaluate their performance for further application in oil recovery at producing and mature oil well sites as well as for the prevention and control of paraffin deposits.

Acknowledgements

The authors would like to extend their gratitude to CNPq, FAPERJ and Petrobras for their financial and technical assistance.

Received: September 9, 2003 [ELS 33]
Received in revised form (last revision): May 10, 2004
Accepted: May 14, 2004

References

[1] C.P. Sanches, Possibilidade de dano por cristalização de parafinas no reservatório: um exemplo do campo de Fazenda Balsamo – Bacia do Recôncavo – BA, *Boletim Técnico da Petrobrás* (Rio de Janeiro) **1991**, 34, 101–112.

[2] G.E. Jenneman, R.M. Knapp, M.J. McInerney, D.E. Menzie, D.E. Revus, Experimental studies of *in-situ* microbial enhanced oil-recovery, *Soc. Petrol. Eng. J.* **1984**, 14, 33–37.

[3] I. Lazar, A. Voicu, C. Nicolescu, D. Mucenica, S. Dobrota, I.G. Petrisor, M. Stefanescu, L. Sandulescu, The use of naturally occurring selectively isolated bacteria for inhibiting paraffin deposition, *J. Petrol. Sci. Eng.* **1999**, 22, 161–169.

[4] J.E. Zajic, D.G. Cooper, T.R. Jack, N. Kosaric, *Microbial Enhanced Oil Recovery*, PennWell Publishing Company, Tulsa **1983**, 14–25.

[5] R.J. Neufeld, J.E. Zalic, D.F. Gerson, Growth-characteristics and cell partitioning of *Acinetobacter* on hydrocarbon substrates, *J. Ferment. Technol.* **1983**, 61, 315–321.

[6] X.Y. Li, S. Lang, F. Wagner, L. Witte, V. Wray, Formation and identification of interfacial-active glycolipids from resting microbial cells, *Appl. Environ. Microbiol.* **1984**, 48, 610–617.

[7] D.S. Francy, J.M. Thomas, R.L. Raymond, C.H. Ward, Emulsification of hydrocarbons by subsurface bacteria, *J. Ind. Microbiol.*, **1991**, 8, 237–245.

[8] K. Behlulgil, T. Mehmetoglu, S. Donmez, Application of microbial enhanced oil-recovery technique to a Turkish heavy oil, *Appl. Microbiol. Biotechnol.* **1992**, 36, 833–835.

[9] G. Voordouw, S.M. Armstrong, M.F. Reimer, B. Fouts, A.J. Telang, Y. Shen, D. Gevertz, Characterization of 16S rRNA genes from oil field microbial communities indicates the presence of a variety of sulfate-reducing, fermentative, and sulfide-oxidizing bacteria, *Appl. Environ. Microbiol.* **1996**, 62, 1623–1629.

[10] J.G. Kuonen, M.J. Robertson, H. Tuovinen, in *The Prokaryotes* (Eds: A. Balows, H.G. Truper, M. Dworkin, W. Harder, K.H. Schleifer), 2nd ed., Vol. 4, Springer Verlag, New York **1992**, 2638–2657.

[11] H.J. Laanbroek, L.J. Stal, H. Veldkamp, Utilization of hydrogen and formate by *Campylobacter* sp. under aerobic and anaerobic conditions, *Arch. Microbiol.* **1978**, 119, 99–102.

[12] G.L. Trebbau, G.J. Nuñez, R.L. Cairra, N.Y. Molina, L.C. Entzeroth, D.R. Schneider, Microbial stimulation of lake Maracaibo oil basin, in *74th Annual Technical Conference and Exhibition of the Society of Petroleum Engineers*, Houston (Texas, USA) **1999**, 1–23, paper number 56503.

[13] T.R. Jack, B.G. Thompson, E. Diblasio, The potential for use of microbes in the production of heavy oil, in *Proceedings of the International Conference on Microbial Enhanced Oil Recovery* (Ed: E.C. Donaldson, J.B. Clark), Afton (Oklahoma, USA) **1982**, 88–93 SPE/DOE, conference number 8205140.

[14] J.B. Clark, D.M. Munnecke, G.E. Jenneman, *In-situ* microbial enhancement of oil production, *Dev. Ind. Microbiol.* **1981**, 22, 695.

[15] R.A. Raiders, Oil recovery and sweep efficiency improvement in parallel core systems due to the metabolism of indigenous microorganisms, *MS Thesis*, University of Oklahoma, Norman (OK, USA) **1986**.

[16] T.R. Jack, B.G. Thompson, Patents employing microorganisms in oil production, in *Microbial Enhanced Oil Recovery* (Eds: J.E. Zajic, D.G. Cooper, T.R. Jack, N. Kosaric), PennWell Publishing Company, Tulsa (USA) **1983**, 14–25.

[17] R.S. Bryant, T.E. Burchfield, K.L. Chase, K.M. Bertus, A.K. Stepp, Optimisation of microbial formulations for oil recovery: mechanisms of oil mobilisation, transport of microbes and metabolites, and effects of additives, in *64th Annual Technical Conference and Exhibition of the Society of Petroleum Engineers*, San Antonio (Texas, USA) **1989**, 567–578, paper number 19686.

[18] M.E. Singer, Microbial processes in the recovery of heavy petroleum, in *Proceedings of International Conference on Microbial Enhanced Oil Recovery* (Eds: E.C. Donaldson, J.B. Clark), SPE/DOE, Afton, Oklahoma, **1982**, 88–93.

[19] J.D. Desai, I.M. Banat, Microbial production of surfactants and their commercial potential, *Microbiol. Mol. Biol. Rev.* **1997**, 61, 47–64.

[20] T.R. Jack, E. Lee, J. Mueller, Anaerobic gas production from crude oil, *J. Int. Biores.* **1985**, 1, 167–185.

[21] M.M. Yakimov, M.M. Amro, M. Bock, K. Boseck, H.L. Fredrickson, D.G. Kessel, K.M. Timmis, The potential of *Bacillus licheniformis* strains for *in-situ* enhanced oil recovery, *J. Petrol. Sci. Eng.* **1997**, 18, 147–160.

[22] J.O. Stephens, L.R. Brown, A.A. Vadie, Microbial permeability profile modification extends life of oil field, *Petroleum Technol. Digest* **2000**, 6, 1–6.

[23] C. Vanderzant, D.F. Splittstoesser, in *Compendium of Methods for the Microbiological Examination of Foods*, 3rd ed., APHA, Washington, DC (USA) **1992**, 173–178.

[24] M.M. Yakimov, K.M. Timmis, V. Wray, H.L. Fredrickson, Characterization of a new lipopeptide surfactant produced by thermotolerant and halotolerant subsurface *Bacillus licheniformis* bas50, *Appl. Environ. Microbiol.* **1995**, 61, 1706–1713.

[25] A.I. Vogel, in *Análise Química Quantitativa*, 5a (Ed: G. Koogan), Rio de Janeiro, **1997**, 712–712.

[26] P. Gerhardt, R.G.E. Murray, W.A. Wood, N.R. Krieg, in *Methods for General and Molecular Bacteriology*, ASM, Washington, DC (USA) **1994**.

[27] J.G. Holt, in *Bergey's Manual of Determinative Bacteriology*, 9th ed., Williams & Wilkins, Baltimore (MD, USA) **1994**, 816, 7.

[28] E. Knetting, J.E. Zajic, Flocculant production from kerosene. *Biotechnol. Bioeng.* **1972**, 14, 179–190.

[29] J.C. Bertrand, P. Bonin, M. Goutx, M. Gauthier, G. Mille, The potential application of biosurfactants in combating hydrocarbon pollution in marine environments, *Res. Microbiol.* **1994**, 145, 53–56.

[30] M.E. Singer, Microbial biosurfactants, *Microbes Oil Rec.* **1985**, 1, 19–38.

- [31] R. S. Maker, S. S. Camorra, Biosurfactants production by a hemophilic *Bacillus*, *J. Ind. Microbiol. Biotechnol.* **1997**, *18*, 37–42.
- [32] R. S. Bryant, T. E. Burchifield, K. L. Chase, K. M. Bertus, A. K. Stepp, Optimisation of microbial formulations for oil recovery: mechanisms of oil mobilisation, transport of microbes and metabolites, and effects of additives, in *64th Annual Technical Conference and Exhibition of the Society of Petroleum Engineers*, San Antonio (Texas, USA) **1989**, 567–578, paper number 19686.
- [33] G. E. Jenneman, M. J. McInerney, R. M. Knapp, Effect of nitrate on biogenic sulfide production, *Appl. Environ. Microbiol.* **1986**, *51*, 1205–1211.